

UNI-ROYAL
厚聲集團

DATA SHEET

Product Name Metal Foil Long side Terminal current sensing Chip Resistor

Part Name MW08、MW12、MW15、MW25 Series

Uniroyal Electronics Global Co., Ltd.

88#, Longteng Road, Economic & Technical Development Zone, Kunshan, Jiangsu, China

Tel +86 512 5763 1411 / 22 /33

Email marketing@uni-royal.cn

Manufacture Plant Uniroyal Electronics Industry Co., Ltd.

Aeon Technology Corporation

Royal Electronic Factory (Thailand) Co., Ltd.

Royal Technology (Thailand) Co., Ltd.

1. Scope

- 1.1 This specification for approve relates to the Metal Foil Long side Terminal current sensing Chip Resistor manufactured by UNI-ROYAL.
- 1.2 Low Resistance / TCR / EMF / Inductance
- 1.3 Excellent long term stability
- 1.4 RoHs compliant and halogen free.
- 1.5 Lead free.
- 1.6 High precision current sensing and voltage division.

2. Part No. System

Part No. includes 14 codes shown as below:

2.1 1st~4th codes: Part name. E.g.: MW08,MW12,MW15,MW25

2.2 5th~6th codes: Power rating.

E.g.: W=Normal Size "1~G" = "1~16"

Wattage	1/32	3/4	1/2	1/3	1/4	1/8	1/10	1/16	1/20	1
Normal Size	WH	07	W2	W3	W4	W8	WA	WG	WM	1W

If power rating is lower or equal than 1 watt, 5th code would be "W" and 6th code would be a number or letter.

E.g.: 1W=1W 4W=4W

2.3 7th code: Tolerance. E.g.: D=±0.5% F=±1% G=±2% J=±5% K= ±10%

2.4 8th~11th codes: Resistance Value.

2.4.1 If value belongs to standard value of ≥5% series, 8th code would be zero,9th~10th codes are significant figures of the resistance and 11th code is the power of ten.

2.4.2 If value belongs to standard value of ≤2% series, 8th~10th codes are significant figures of the resistance, and 11th code is the power of ten.

2.4.3 11th codes listed as following:

0=10⁰ 1=10¹ 2=10² 3=10³ 4=10⁴ 5=10⁵ 6=10⁶ J=10⁻¹ K=10⁻² L=10⁻³ M=10⁻⁴ N=10⁻⁵ P=10⁻⁶

2.5 12th~14th codes.

2.5.1 12th code: Packaging Type. E.g.: C=Bulk T=Tape/Reel

2.5.2 13th code: Standard Packing Quantity.

4=4000pcs 5=5000pcs C=10000pcs D=20000pcs E=15000pcs

Chip Product: BD=B/B-20000pcs TC=T/R-10000pcs

2.5.3 14th code: Special features.

E = Environmental Protection, Lead Free, or Standard type.

3. Ordering Procedure

(Example: MW12 1.5W ±1% 3mΩ T/R-5000)

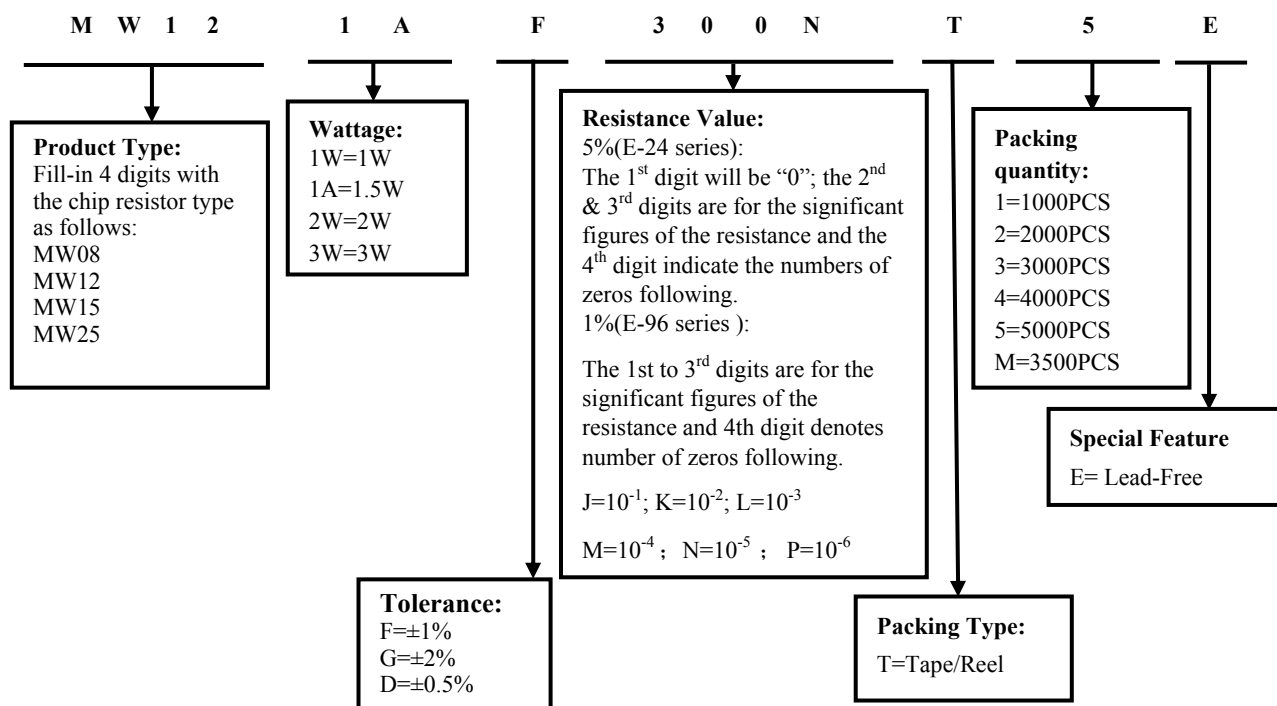

4. Standard Electrical Specifications

Type	Rating Power at 70°C	T.C.R. (ppm/°C)	Max. Rating Current	Max. Overload Current	Resistance Range (mΩ)			Material	Operating Temperature Range (°C)
					0.5%(D)	1.0%(F)	2.0%(G)		
MW08	1W	±100	31.62A	50A	/	/	1	R001~R009: MnCu R010~R100: Cu Alloy	- 55 ~ + 155
		±100	22.36A	35.35A		2~9	/		
		±50	10A	15.81A	10~100		/		
MW12	1.5W	±100	38.72A	61.23A	/	/	1	R001~R009: MnCu R010~R100: Cu Alloy	
		±100	27.38A	43.30A		2~9	/		
		±50	12.24A	19.36A	10~100		/		
MW15	2W	±100	44.72A	70.71A	/	/	1	R001~R020: Cu Alloy	
		±100	31.62A	50A	/	2~9	/		
		±50	14.14A	22.36A	10~20		/		
MW25	3W	±100	54.77A	86.60A	/	1~9	/	R001~R020: MnCu	
		±50	17.32A	27.38A	10~100		/	R021~R100: Cu Alloy	

5. Dimension

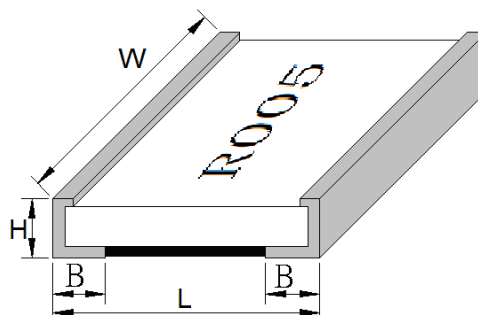

Unit:mm

Type	Power Rating	Resistance Range	L	W	H	B
MW08 (0508)	1W	1~100mΩ	1.35±0.20	2.10±0.20	0.65±0.20	0.43±0.20
MW12 (0612)	1.5W	1mΩ	1.60±0.25	3.20±0.25	0.65±0.20	0.50±0.30
		2mΩ~100mΩ				0.40±0.20
MW15 (0815)	2W	1~20mΩ	2.20±0.20	3.80±0.20	0.65±0.20	0.61±0.20
MW25 (1225)	3W	1~100mΩ	3.20±0.30	6.40±0.30	0.65±0.20	0.60±0.20

6. Structure

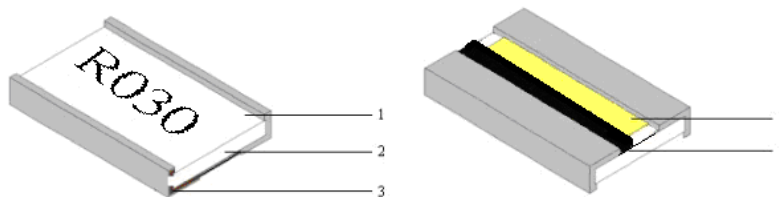

1	Marking	4	Resistance layer
2	Alumina Substrate	5	Protective layer
3	Terminal (Cu/Ni/ Sn)		

7. Marking

“R” designates the decimal location in ohms e.g. 1mΩ the product marking is R001.

20mΩ the product marking is R020.

“M” designates the decimal location in milli-ohms

e.g. 5.5mΩ the product marking is 5M50.

8. Recommend land pattern

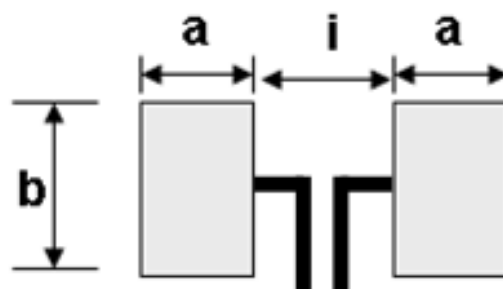

Unit:mm				
Type	Resistance Range	a	b	i
MW08 1W	1~100mΩ	1.10	2.30	0.60
MW12 1.5W	1m Ω	1.35	3.68	0.50
	2m Ω ~100m Ω	1.30	3.68	0.60
MW15 2W	1~20mΩ	2.40	4.26	0.70
MW25 3W	1~100mΩ	2.35	7.25	1.40

9. Derating Curve

The Operating Temperature Range: -55°C ~+155°C.

For resistors operated in ambient temperatures above 70°C, power rating must be derated in accordance with the curve below(Terminal temperature derating from above 100°C)

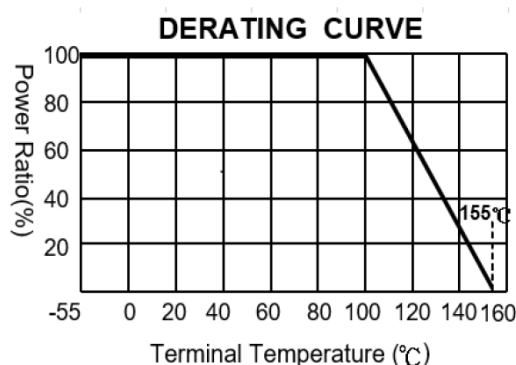
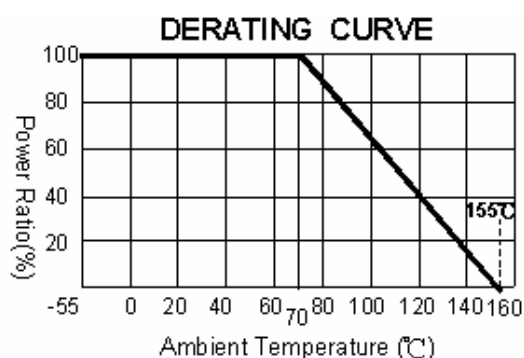

The following equation may be used to determine the DC (Direct Current) or AC (Alternating Current) (RMS, root mean square value) of normal rated power. However, if the result value exceeds the highest current of regulated standards (paragraph 5), the highest normal rated power is to be used

$$I = \sqrt{P \div R}$$

I = Rating current (A)

P= Rating Power (W)

R= Resistance(Ω)

10. Performance Specification

Test Item	Test Method	Procedure	Requirements
Temperature Coefficient of Resistance (T.C.R)	JIS C 5201-1 clause 4.8	$T.C.R. (ppm/^{\circ}C) = \frac{R2-R1}{R1(T2-T1)} \times 10^6 (PPM/^{\circ}C)$ R1: resistance at room temperature (T1) R2: resistance at 125°C (T2)	Refer to Ratings
Short Time Overload	JIS C 5201-1 clause 4.13	The number of rated power are as follows: 2.5 times of rated power Rating power duration: 5secs	±1.0%+0.5mΩ
High Temperature Exposure	JIS C 5201-1 clause 4.23.2	1,000hrs at + 155 °C±2°C	±1.0%+0.5mΩ
Low Temp. Storage	JIS C 5201-1 clause 4.23.4	1,000hrs at -55 °C±2°C	±1.0%+0.5mΩ
Soldering Heat	JIS C 5201-1 clause 4.18	260±5°C for 10±1 seconds.	±1.0%+0.5mΩ
Moisture Load Life	JIS C 5201-1 clause 4.24	T=40±2°C,RH=90~95% ,Load with Rated Current 1.5hrs "ON", 0.5hrs "OFF", 1000h	±2.0%+0.5mΩ
Temperature Cycling	JIS C 5201-1 clause 4.19	-55°C to +155°C, 100 cycles	±1.0%+0.5mΩ

Load Life	JIS C 5201-1 clause 4.25	T=70±2 °C, Load with Rated Current 1.5hrs “ON”, 0.5hrs “OFF”, 1000h	±2.0%+0.5mΩ
Solderability	JIS C 5201-1 clause 4.17	245±5°C for 3±0.5secs	The covered area >95%
Mechanical Shock	JIS C 5202 clause 6.7	a =50G , t =11ms, 5 times shock	±1.0%+0.5mΩ
Bending Strength	JIS-C-5201-1 4.33 IEC-60115-1 4.33	Bending once 2mm for 10 seconds	±1.0%+0.5mΩ

11. Recommended Customer Soldering Parameters

11.1. Wave solder Temperature condition

Preheating : 100°C~130°C, max.100 sec.

Soldering: 250°C~265°C max. 10 sec.

Maximum temperature : 260±5°C, max. 10sec.

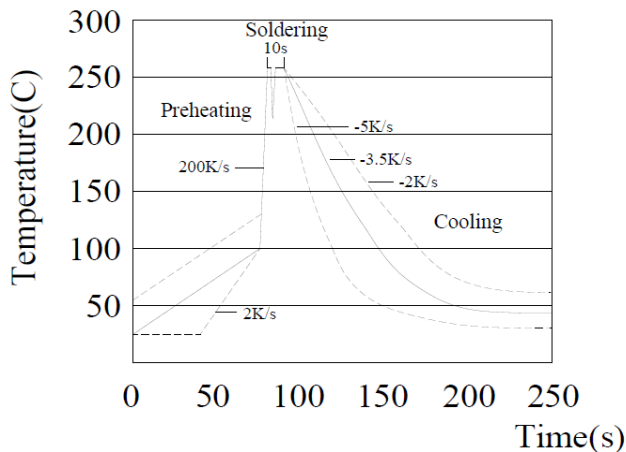

11.2 Solder reflow Temperature condition

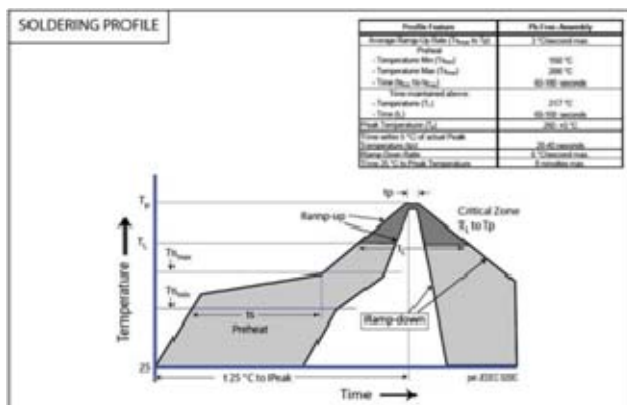

11.3 Rework temperature (hot air equipment) : 350°C, 3~5seconds

11.4 Recommended reflow methods

IR, vapor phase oven, hot air oven

If reflow temperatures exceed the recommended profile, devices may not meet the performance requirements.

12. Packing

12.1 Carrier Dimensions:(Unit: mm)

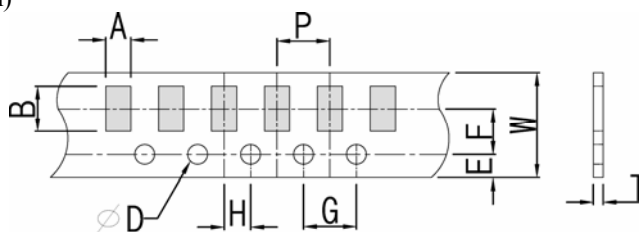

Item	W	P	E	F	ψD	G	H	A	Bo	T
MW08	8.0±0.30	4.0±0.10	1.75±0.10	3.5±0.10	1.50+0.1/-0	4.0±0.10	2.0±0.10	1.68±0.20	2.38±0.20	0.87±0.20
MW12								2.05±0.20	3.65±0.20	0.87±0.10

12.2 Embossed Dimensions:(Unit: mm)

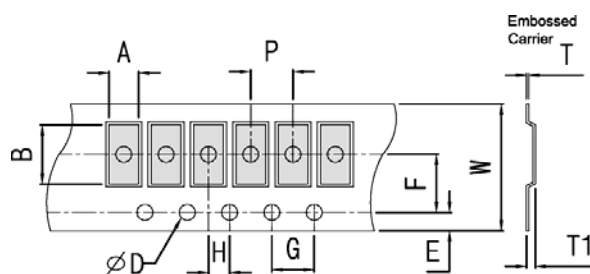

Item	W	P	E	F	ϕD	G	H	A	B	T1	T
MW15	12.0±0.30	4.0±0.10	1.75±0.10	5.5±0.10	1.50+0.1/-0	4.0±0.10	2.0±0.10	3.40±0.20	6.75±0.20	1.00±0.20	0.25±0.10
MW25	12.0±0.30	4.0±0.10	1.75±0.10	5.5±0.10	1.50+0.1/-0	4.0±0.10	2.0±0.10	3.40±0.20	6.75±0.20	1.00±0.20	0.25±0.10

12.3 Reel Dimensions : (Unit: mm)

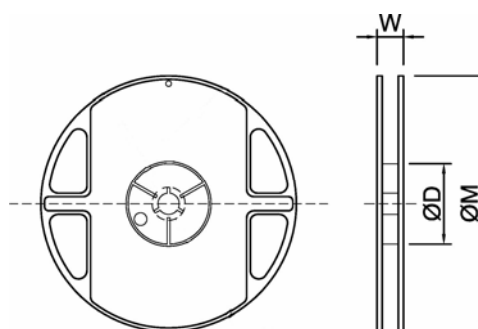

TYPE	Qty/Reel	ϕD	W	ϕM
MW08	5,000pcs	60±2	9.0±1	178±5
MW12	5,000pcs	60±2	9.0±1	178±5
MW15	4,000pcs	60±2	13.0±1	178±5
MW25	4,000pcs	60±2	13.0±1	178±5

12. Note

13.1 UNI-ROYAL recommend the storage condition temperature: $25 \pm 5^{\circ}\text{C}$, humidity : $60 \pm 20\%$.

(Put condition for individual product).

Even under UNI-ROYAL recommended storage condition, solderability of products over 1 year old. (Put condition for each product) may be degraded.

13.2 Store / transport cartons in the correct direction, which is indicated on a carton as a symbol.

Otherwise bent leads may occur due to excessive stress applied when dropping of a carton.

13.3 Product performance and soldered connections may deteriorate if the products are stored in the following places:

- a. Storage in high Electrostatic.
- b. Storage in direct sunshine、rain and snow or condensation.
- c. Where the products are exposed to sea winds or corrosive gases, including Cl_2 , H_2S , NH_3 , SO_2 , NO_2 .

13. Record

Version	Description of amendment	Page	Date	Amended by	Checked by
1	First issue of this specification	1~7	Jun.05, 2019	Haiyan Chen	Yuhua Xu
2	Add the MW08 MW25 Type	1~7	Nov.11, 2019	Haiyan Chen	Yuhua Xu
3	Modify product name	1~7	Nov.26, 2019	Haiyan Chen	Yuhua Xu
4	1. Add the MW15 2. Add the 2% tolerance 3. Add the terminal temperature	1~8 3 5	May.26, 2020	Haiyan Chen	Yuhua Xu

© Uniroyal Electronics Global Co., Ltd. All rights reserved. Specification herein will be changed at any time without prior notice