



UNI-ROYAL
厚聲集團

DATA SHEET

Product Name High-Precision Thin Film Chip Resistors

Part Name TC Series

Uniroyal Electronics Global Co., Ltd.

88 Longteng Road, Economic & Technical Development Zone, Kunshan, Jiangsu, China

Tel +86 512 5763 1411 / 22 /33

Email marketing@uni-royal.cn

Manufacture Plant Uniroyal Electronics Industry (kunshan) co., ltd.
Uniroyal Electronics Industry Co., Ltd.
Uniroyal Electronics Global Co.,Ltd Shenzhen Branch
Aeon Technology Corporation
Uniroyal Electronics Global Co.,Ltd Xiamen Branch
Kunshan Foss Electronic material Co., Ltd.

Brands **RoyalOhm** **UniOhm**

1. Scope

- 1.1 This specification for approve relates to the High Precision Thin Film Chip Resistors manufactured by UNI-ROYAL.
- 1.2 Thin film NiCr Resistance element.
- 1.3 Very tight tolerance $\pm 0.05\% \sim \pm 1\%$
- 1.4 Extremely low TCR $\pm 5\text{ppm} \sim \pm 50\text{ppm}$
- 1.5 Completed Lead-free

2. Explanation of Part No. System

Part No. includes 14 codes shown as below:

2.1 This is to indicate the Lead-Free High Precision Thin Film Chip Resistors

Example: TC02, TC03, TC05, TC06, TC07, TC10, TC12

2.2 5th~6th digits:

For Thin Film Chip Resistors, these 2 digits will be used to indicate the requested Temperature Coefficient.

(1) 05=5PPM (2) 10=10PPM (3) 15=15PPM (4) 25=25PPM (5) 50=50PPM

2.3 The 7th digit is to denote the Resistance Tolerance. The following letter code is to be used for indicating the standard Resistance Tolerance.

B= $\pm 0.10\%$ C= $\pm 0.25\%$ D= $\pm 0.50\%$ F= $\pm 1.00\%$

2.4 The 8th to 11th digits is to denote the Resistance Value.

2.4.1 For the standard resistance values of TC series, the 8th digit to the 10th digits is to denote the significant figures of the resistance and the 11th digit is the zeros following.

2.4.2 The following number s and the letter codes is to be used to indicate the number of zeros in the 11th digit:

0= 10^0 1= 10^1 2= 10^2 3= 10^3 4= 10^4 5= 10^5 6= 10^6 J= 10^{-1} K= 10^{-2} L= 10^{-3} M= 10^{-4}

2.4.3 The 12th, 13th & 14th digits.

The 12th digit is to denote the Packaging Type with the following codes:

C=Bulk in (Chip Product) T=Tape/Reel

2.4.4 The 13th digit is normally to indicate the Packing Quantity of Tape/Box & Tape/Reel packaging types. The following letter code and number is to be used for some packing quantities:

4=4000pcs 5=5000pcs C=10000pcs D=20000pcs E=15000pcs

Chip Product: BD=B/B-20000pcs TC=T/R-10000pcs

2.4.5 The 14th digit

This is to indicate the wattage or power rating:

B=1/32W; C=1/16W; F=1/10W; G=1/8W; H=1/6W;

J=1/4W; K=1/3W; M=1/2W; N=3/4W; P=1W;

S=Special

3. Ordering Procedure

(Example: TC06 1/3W $\pm 0.1\%$ 25PPM 1K Ω T/R-5000)

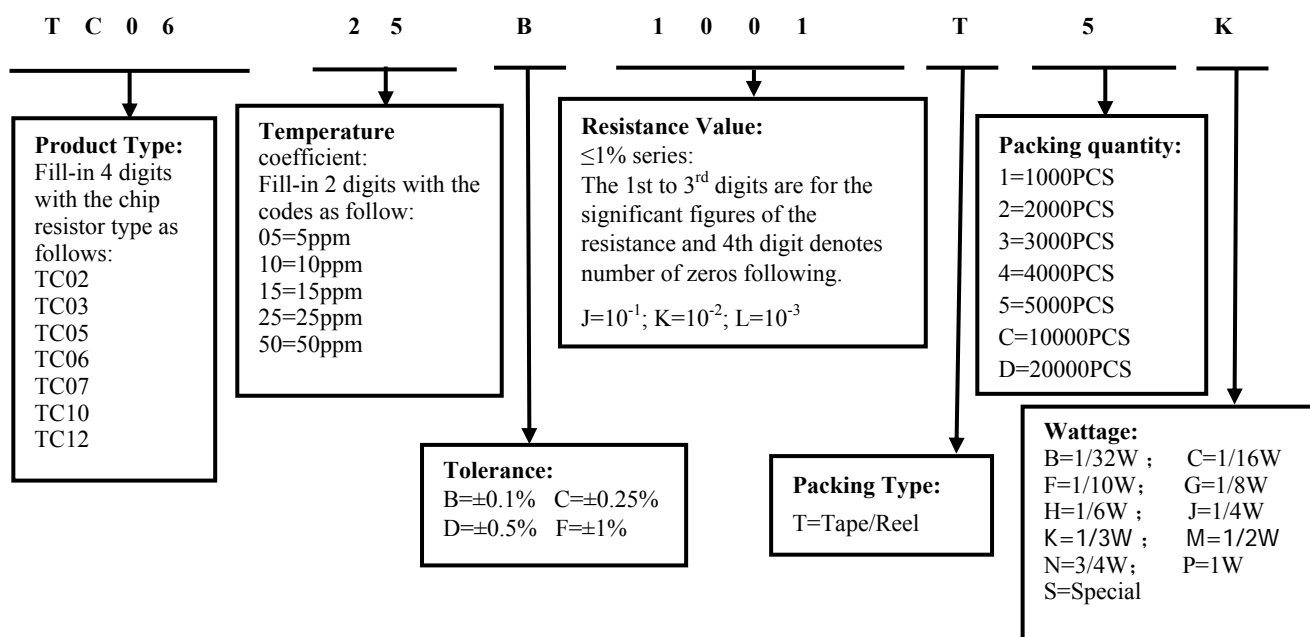

4. Marking

(1) For TC02 size. Due to the very TC02 small size of the resistor's body, there is no marking on the body.



(2) $\pm 0.1\%$ 、 $\pm 0.25\%$ 、 $\pm 0.5\%$ 、 $\pm 1\%$ Tolerance:
 4 digits, first three digits are significant; fourth digit is number of zeros. Letter r is decimal point.



2701 → 2.7KΩ

5. Dimension

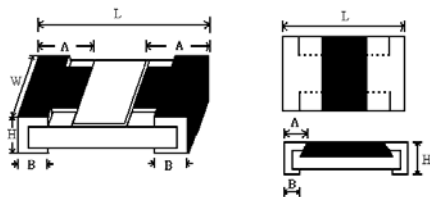

Type	L	W	H	A	B
TC02(0402)	1.00±0.10	0.50±0.05	0.35±0.05	0.20±0.10	0.25±0.10
TC03(0603)	1.60±0.10	0.80±0.10	0.45±0.10	0.30±0.20	0.30±0.20
TC05(0805)	2.00±0.15	1.25±0.15/-0.10	0.55±0.10	0.40±0.20	0.40±0.20
TC06(1206)	3.10±0.15	1.55±0.15/-0.10	0.55±0.10	0.45±0.20	0.45±0.20
TC07((1210)	3.10±0.10	2.60±0.20	0.55±0.10	0.45±0.20	0.45±0.20
TC10(2010)	5.00±0.10	2.50±0.20	0.55±0.10	0.60±0.25	0.50±0.20
TC12(2512)	6.35±0.10	3.20±0.20	0.55±0.10	0.60±0.25	0.50±0.20

6. Resistance Range

Type	Power rating At 70°C	TCR (PPM/°C)	Resistance Range					Max. Operating voltage	Max. Overloading voltage	
			±0.05%	±0.1%	±0.25%	±0.5%	±1%			
TC02	1/16W	±5	49.9Ω~20K	10Ω~20K			25V	50V		
		±10, ±15		10Ω~100K						
		±25, ±50	49.9Ω~12K	10Ω~511K	4.7Ω~511K					
TC03	1/6W	±5	-	10Ω~2K			75V	150V		
		±10, ±15	-	10Ω~10K						
		±25, ±50	10Ω~332K	4.7Ω~1M	1.5Ω~1M	1Ω~1M				
	1/10W	±5	24.9Ω~15K	10Ω~15K			75V	150V		
		±10, ±15	4.7Ω~332K	4.7Ω~332K						
		±25, ±50		4.7Ω~1M	1.5Ω~1M	1Ω~1M				
1/16W	±5	24.9Ω~60K	10Ω~60K			50V	100V			
	±10, ±15	4.7Ω~332K	4.7Ω~511K							
	±25, ±50		4.7Ω~1M	1Ω~1M	1Ω~1M					
TC05	1/4W	±5	-	10Ω~2K			150V	300V		
		±10, ±15	-	10Ω~10K						
		±25, ±50	10Ω~499K	10Ω~1M						
	1/8W	±5	24.9Ω~30K	10Ω~30K			150V	300V		
		±10	4.7Ω~511K	4.7Ω~511K						
		±15		4.7Ω~1M						
	±25, ±50	4.7Ω~511K	4.7Ω~1M	1Ω~1M						
			1/10W	±5	24.9Ω~150K	10Ω~150K			100V	200V
				±10, ±15	4.7Ω~1M	4.7Ω~1M				
±25, ±50	4.7Ω~2M	1Ω~1M								
TC06	1/3W	±5	-	10Ω~2K			200V	400V		
		±10, ±15	-	10Ω~10K						
		±25, ±50	10Ω~1M	10Ω~1M						
	1/4W	±5	24.9Ω~49.9K	24.9Ω~49.9K			200V	400V		

TC07	1/8W	±10, ±15	4.7Ω~1M	4.7Ω~1M		150V	300V
		±25, ±50		4.7Ω~1M	1Ω~1M		
		±5	24.9Ω~300K	24.9Ω~300K			
	1/3W	±10, ±15	4.7Ω~1.5M	4.7Ω~1.5M			
		±25, ±50		4.7Ω~2.49M	1Ω~2.49M		
		±5	24.9Ω~49.9K	10Ω~49.9K			
TC10	1/3W	±10, ±15	4.7Ω~1M	4.7Ω~1M		200V	400V
		±25, ±50		4.7Ω~1M	1Ω~1M		
		±5	24.9Ω~49.9K	24.9Ω~49.9K			
	1/4W	±10, ±15	4.7Ω~1M	4.7Ω~1M			
		±25, ±50		4.7Ω~2.49M	1Ω~2.49M		
		±5	24.9Ω~300K	10Ω~300K			
TC12	1W	±10, ±15	-	10Ω~10K		200V	400V
		±25, ±50		4.7Ω~1M	1Ω~1M		
		±5	-	10Ω~2K			
	3/4W	±10, ±15	4.7Ω~2K	4.7Ω~10K	1Ω~10K		
		±25, ±50		4.7Ω~1M	1Ω~1M		
		±5	24.9Ω~499K	10Ω~300K			
1/2W	±10, ±15	4.7Ω~1M	4.7Ω~1M				
	±25, ±50		4.7Ω~3M	1Ω~3M			

7. Recommend the size of welding plate

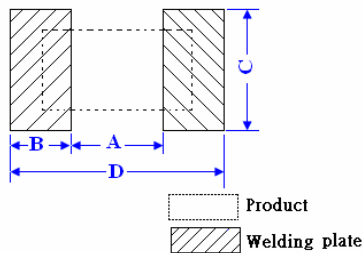

Type	Dimension(mm)			
	A	B	C	D
TC02	0.50±0.05	0.45±0.05	0.5±0.05	1.4±0.05
TC03	0.8±0.05	0.65±0.05	0.8±0.05	2.1±0.05
TC05	1.0±0.1	1.0±0.1	1.3±0.1	3.0±0.1
TC06	2.0±0.1	1.1±0.1	1.6±0.1	4.2±0.1
TC07	2.0±0.1	1.1±0.1	2.6±0.1	4.2±0.1
TC10	3.6±0.1	1.3±0.1	2.6±0.1	6.2±0.1
TC12	4.9±0.1	1.6±0.1	3.3±0.1	8.1±0.1

8. Derating Curve

Resistors shall have a power rating based on continuous load operation at an ambient temperature from -55°C to 70°C. For temperature in excess of 70°C, the load shall be derated as shown in figure 1

Figure 1

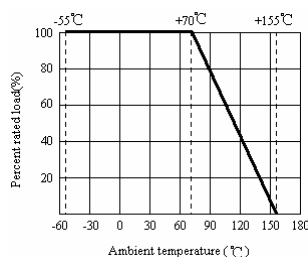

8.1 Voltage rating:

Resistors shall have a rated direct-current (DC) continuous working

Voltage or an approximate sine-wave root-mean-square (RMS) alternating-current (AC) continuous working voltage at commercial-line frequency and waveform corresponding to the power rating, as determined from the following formula:

$$RCWV = \sqrt{P \times R}$$

Where: RCWV commercial-line frequency and waveform (Volt.)

P = power rating (WATT.)

R = nominal resistance (OHM)

In no case shall the rated DC or RMS AC continuous working voltage be greater than the applicable maximum value.

The overload voltage is 2.5 times RCWV or Max. Overload voltage whichever is less

9. Structure

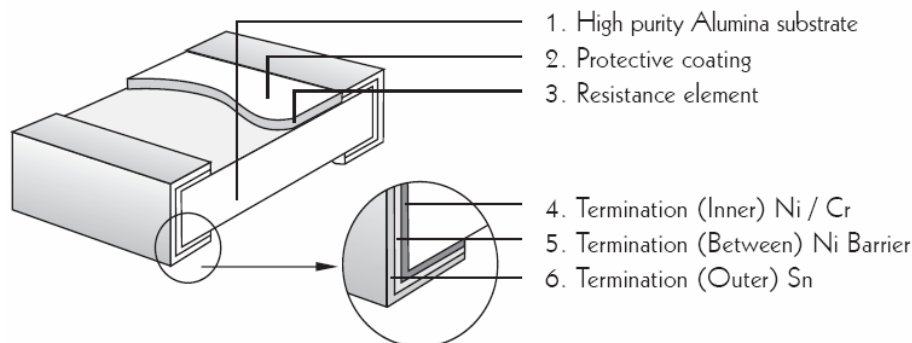

10. Performance Specification

Characteristic	Limits	Test Method (JIS-C-5201 & JIS-S-5202)
Temperature Coefficient	Refer to item 2.0	$\frac{R_2 - R_1}{R_1(t_2 - t_1)} \times 10^6 \text{ (PPM/}^\circ\text{C)}$ $\frac{R_3 - R_1}{R_1(t_3 - t_1)} \times 10^6 \text{ (PPM/}^\circ\text{C)}$ <p> R_1: Resistance Value at room temperature (t_1) ; R_2: Resistance Value at upper limit temperature $\pm 2^\circ\text{C}$ (t_2) R_3: Resistance Value at lower limit temperature $\pm 3^\circ\text{C}$ (t_3) Test pattern : Room temperature : (t_1) Upper limit temperature : (t_2) Lower limit temperature : (t_3) </p>
Short-time overload	$\Delta R \leq \pm 0.5\%$	4.13 Permanent resistance change after the application of a potential of 2.5 times RCWV or Max. Overload Voltage whichever less for 5 seconds..
Insulation resistance	$\cong 1000\text{M}\Omega$	4.6 The measuring voltage shall be ,measured with a direct voltage of (100 \pm 15)V or a voltage equal to the dielectric withstanding voltage., and apply for 1min
Load life	$\Delta R \leq \pm 0.2\%$ $> 7\text{K}\Omega \Delta R \leq \pm 0.5\%$	4.25 Permanent resistance change after 1,000 hours operating at RCWV with duty cycle 1.5 hours "ON", 0.5 hour "OFF" at 70 $^\circ\text{C}$ $\pm 2^\circ\text{C}$ ambient.
Humidity	$\Delta R \leq 0.3\%$	4.24 Temporary resistance change after 240 hours exposure in a humidity test chamber controlled at 40 $\pm 2^\circ\text{C}$ and 90-95% relative humidity,
Terminal bending	$\Delta R \leq \pm 0.2\%$	4.33 Twist of test board: Y/X = 3/90 mm for 60Seconds
Solderability	95% coverage min.	4.17 Wave solder: Test temperature of solder: 245 $^\circ\text{C}$ $\pm 3^\circ\text{C}$ dipping time in solder: 2-3 seconds.
Soldering heat	$\Delta R \leq \pm 0.2\%$	4.18 Dip the resistor into a solder bath having a temperature of 260 $^\circ\text{C}$ $\pm 5^\circ\text{C}$ and hold it for 10 \pm 1 seconds.

Load life in humidity	$\Delta R \leq \pm 0.5\%$	7.9 Resistance change after 1,000 hours (1.5 hours "ON", 0.5 hour "OFF") at RCWV in a humidity chamber controlled at $40^\circ\text{C} \pm 2^\circ\text{C}$ and 90 to 95% relative humidity.
Low Temperature Storage	$\Delta R \leq \pm 0.2\%$ $>7\text{K}\Omega \Delta R \leq \pm 0.5\%$	4.23.4 Lower limit temperature , for 2H.
High Temperature Exposure	$\Delta R \leq \pm 0.2\%$ $>7\text{K}\Omega \Delta R \leq \pm 0.5\%$	4.23.2 Upper limit temperature , for 16H.
Leaching	No visible damage	J-STD-002 Test D Samples completely immersed for 30 sec in solder bath at 260°C .
Rapid change of temperature	$\Delta R \leq \pm 0.2\%$ $>7\text{K}\Omega \Delta R \leq \pm 0.5\%$	4.19 30 min at lower limit temperature and 30 min at upper limit temperature , 5 cycles.

11. Packing of Surface Mount Resistors

11.1 Dimension of Paper Taping :(Unit: mm)

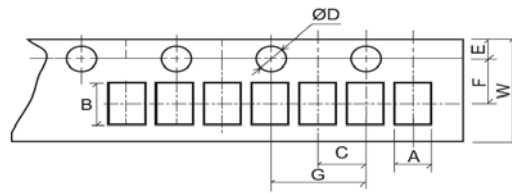

Type	A ± 0.10	B ± 0.10	C ± 0.05	$\begin{matrix} +0.1 \\ \Phi D \\ -0 \end{matrix}$	E ± 0.1	F ± 0.05	G ± 0.1	W ± 0.2	T ± 0.05
TC02	0.65	1.20	2.00	1.50	1.75	3.50	4.00	8.00	0.42

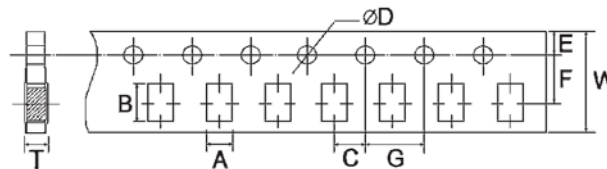

Type	A ± 0.2	B ± 0.2	C ± 0.05	$\begin{matrix} +0.1 \\ \Phi D \\ -0 \end{matrix}$	E ± 0.1	F ± 0.05	G ± 0.1	W ± 0.2	T ± 0.1
TC03	1.10	1.90	2.00	1.50	1.75	3.50	4.00	8.00	0.67
TC05	1.65	2.40	2.00	1.50	1.75	3.50	4.00	8.00	0.81
TC06	2.00	3.60	2.00	1.50	1.75	3.50	4.00	8.00	0.81
TC07	2.80	3.50	2.00	1.50	1.75	3.50	4.00	8.00	0.75

11.2 Dimension of Embossed Taping: (Unit: mm)

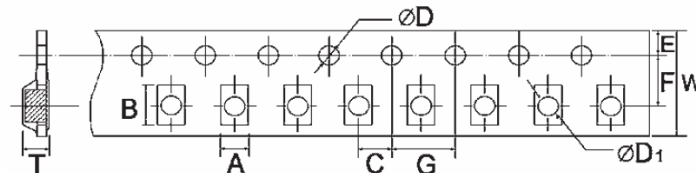

Type	A ± 0.2	B ± 0.2	C ± 0.05	$\begin{matrix} +0.1 \\ \Phi D \\ -0 \end{matrix}$	$\begin{matrix} +0.25 \\ \Phi D1 \\ -0 \end{matrix}$	E ± 0.1	F ± 0.05	G ± 0.1	W ± 0.2	T ± 0.1
TC10	2.90	5.60	2.00	1.50	1.50	1.75	5.50	4.00	12.00	1.00
TC12	3.50	6.70	2.00	1.50	1.50	1.75	5.50	4.00	12.00	1.00

11.3 Dimension of Reel : (Unit: mm)

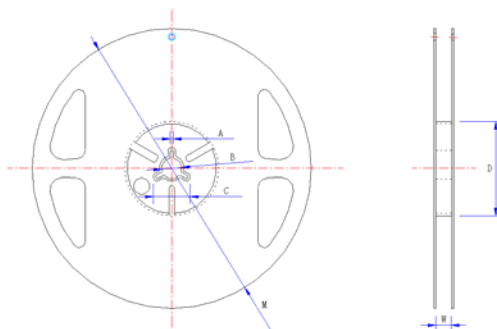

Type	Taping	Qty/Reel	A ±0.5	B ±0.5	C ±0.5	D ±1	M ±2	W ±1
TC02	Paper	10,000pcs	2.0	13.0	21.0	60.0	178.0	10.0
TC03	Paper	5,000pcs	2.0	13.0	21.0	60.0	178.0	10.0
TC05	Paper	5,000pcs	2.0	13.0	21.0	60.0	178.0	10.0
TC06	Paper	5,000pcs	2.0	13.0	21.0	60.0	178.0	10.0
TC07	Paper	5,000pcs	2.0	13.0	21.0	60.0	178.0	10.0
TC10	Embossed	4,000pcs	2.0	13.0	21.0	60.0	178.0	13.8
TC12	Embossed	4,000pcs	2.0	13.0	21.0	60.0	178.0	13.8

12. **Note**

12.1. UNI-ROYAL recommend the storage condition temperature: 15°C~35°C, humidity :25%~75%.

(Put condition for individual product).Even under UNI-ROYAL recommended storage condition, solderability of products over 1 year old.
(Put condition for each product) may be degraded.

12.2. Store / transport cartons in the correct direction, which is indicated on a carton as a symbol.

Otherwise bent leads may occur due to excessive stress applied when dropping of a carton.

12.3. Product performance and soldered connections may deteriorate if the products are stored in the following places:

- Storage in high Electrostatic.
- Storage in direct sunshine 、rain and snow or condensation.
- Where the products are exposed to sea winds or corrosive gases, including Cl₂, H₂S₃, NH₃, SO₂, NO₂.

13. **Record**

Version	Description of amendment	Page	Date	Amended by	Checked by
1	First issue of this specification	1~7	Mar.20, 2018	Chen Haiyan	Chen Nana

Uniroyal Electronics Global Co., Ltd. , all rights reserved. Spec. herein would be changed at any time without prior notice.